

CMV

Vertical, multistage centrifugal pumps 50 Hz



1. General description	3	21. Accessories	37
Introduction	3	Pipework connections	37
2. Overview	4	MP 204 motor protector	40
3. Applications	5	Cover for CMV motor	40
4. Features and benefits	7	Angled cable gland	40
5. Identification	8	22. Further product documentation	41
Type key	8	WebCAPS	41
6. Product range	9	WinCAPS	42
7. Performance range	10		
CMV, 50 Hz	10		
8. Operating conditions	11		
Environmental rating	11		
9. Pumped liquids	13		
List of pumped liquids	13		
10. Construction	16		
Pump	16		
Motor	16		
Frequency converter operation	16		
Shaft seal	17		
Material specification	19		
11. Grundfos CUE	20		
CMV pumps connected to Grundfos CUE frequency converters	20		
12. Approvals and markings	21		
Approvals	21		
Markings	21		
13. Certificates	22		
14. Selection and sizing	24		
Selection of pumps	24		
15. How to read the curve charts	26		
Guidelines to performance curves	26		
16. Performance curves, CMV, 50 Hz	27		
CMV 3	27		
CMV 5	28		
17. Dimensions, CMV 50 Hz	29		
CMV 3	29		
CMV 5	30		
18. Weights and shipping volumes	31		
19. Motor data	32		
Mains-operated motors, 50 Hz	32		
20. Customisation	33		
Motors	33		
Pumps	36		

1. General description

Introduction

The Grundfos CMV pumps are non-self-priming, vertical, multistage centrifugal pumps. The pumps are of the close-coupled type. CMV pumps are fitted with mechanical shaft seals.

The CMV pumps are available in cast iron (EN-GJL-200).

- The impeller and chamber are made of stainless steel (EN 1.4301/AISI 304).
- The drain and filling plugs are made of stainless steel (EN 1.4404/AISI 316L).
- The pump shaft is made of stainless steel (EN 1.4057/AISI 431).



TM05 0727 1511

Fig. 1 Grundfos CMV pumps

The CMV pumps are unique products that have been developed in order to fulfil a wide variety of customer demands.

The CMV pumps are available in various sizes and numbers of stages to provide the flow and pressure required.

The CMV pumps consist of two main components: the motor and the pump unit.

The motor is a Grundfos motor designed to EN standards.

The pump unit incorporates optimised hydraulics and offers various types of connections.

The pumps offer many advantages, some of which are listed below and described in detail in *4. Features and benefits* on page 7:

- compact design
- worldwide usage
- high reliability
- service-friendly
- wide performance range
- low noise
- customised solutions.

2. Overview



Applications



Pages 5 and 6

Identification



Page 8

Product range



Page 9

Operating conditions

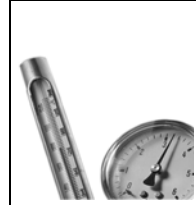

Pages 11 and 12

Construction

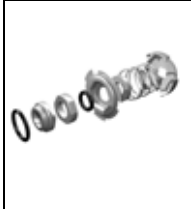

Pages 16 to 19

Certificates and approvals

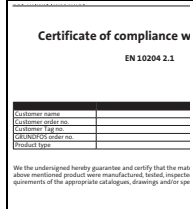

Pages 22 and 23

Selection and sizing



Pages 24 and 25

Pipe connections



Pages 25 and 37

Performance curves

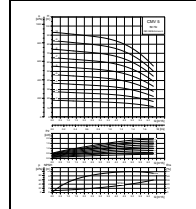

Pages 27 and 28

Dimensions

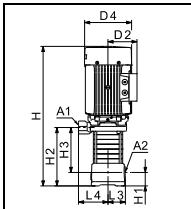

Pages 29 and 30

Motor data



Pages 32

Customisation



Page 33 to 36

Accessories

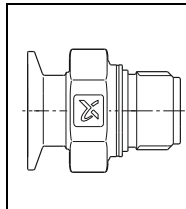

Pages 37 to 40

Further product information



Pages 41 and 42

3. Applications

The CMV pumps are designed to cover a wide variety of applications, ranging from small domestic installations to small industrial systems. The pumps are therefore suitable for a wide diversity of pumping systems where the performance and material of the pump must meet specific demands.

Some of the most typical applications are mentioned below:

- washing and cleaning
- pressure boosting
- temperature control.

Washing and cleaning



G13572

Fig. 2 Washing and cleaning

CMV pumps can be used in washing and cleaning applications, which usually involve pumping of water containing soap or other cleaning agents.

Reference applications

Typical washing and cleaning applications:

- degreasing and washing of production equipment in industrial environments such as the food and beverage industry
- washing machines
- vehicle-washing tunnels
- mobile-washing units
- units for CIP (Cleaning In Place).

Pressure boosting



G10526

Fig. 3 Pressure boosting

In pressure-boosting applications, the pumped liquid must be delivered at a desired pressure on demand. The main priorities in pressure-boosting applications are to ensure maximum reliability and user comfort. Therefore, the CMV pumps are also ideal for such applications.

Reference applications

Typical pressure-boosting applications:

- pressure boosting and transfer of drinking water
- process-water systems.

Temperature control

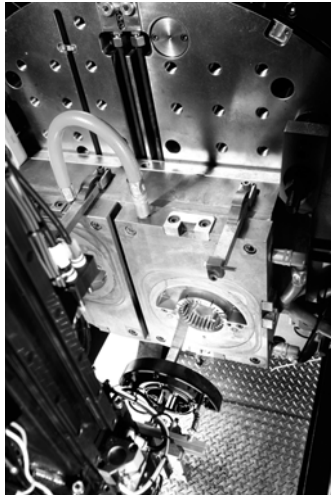

GrA6288

Fig. 4 Temperature control

Temperature control involves applications where the CMV pumps circulate a liquid in a closed loop consisting of a heating or cooling element for optimising a process by means of temperature. Temperature control is also chilling of equipment or food and beverage in the food production industry.

Reference applications

The CMV pumps can for example be used in temperature control systems such as:

- electronic data processing
- laser equipment
- medical equipment
- industrial refrigeration
- heating and cooling in industrial processes
- moisturising and humidifying.

To ensure safe and reliable operation in applications involving temperature control, we offer CMV pumps designed to meet your requirements!

We provide solutions for applications involving pumping of these liquids:

- liquids at temperatures down to $-20\text{ }^{\circ}\text{C}$
- high-temperature liquids
- high-viscous liquids, etc.

Pumping of liquids at temperatures down to $-20\text{ }^{\circ}\text{C}^*$

When pumping liquids at temperatures down to $-20\text{ }^{\circ}\text{C}$, it is crucial that the pump parts are made of the right materials and have the right dimensions.

At such low temperatures, the selection of wrong materials and dimensions may cause deformation because of thermal expansion, and eventually stoppage of operation.

Pumping of high-viscous liquids

In applications where high-viscous liquids are pumped, the motor of the pump can be overloaded, and the pump performance will be reduced.

The viscosity of a pumped liquid depends strongly on the pumped liquid and its temperature.

To meet the above-mentioned requirements, we offer CMV pumps with oversize motors.

4. Features and benefits



TM05 0727 1511

Fig. 5 CMV pumps

CMV pumps offer the following features and benefits:

Compact design

Pump and motor are integrated in a compact and user-friendly design.

Modular construction/customised solutions

The modular construction of the CMV pumps makes it easy to create many different variants based on standard factory parts. This means that it is possible to create pump variants that are customised for the application in question.

Worldwide usage

- CMV pumps are as standard available with single- and three-phase motors suitable for 50 Hz voltage supplies. Other voltage and frequency combinations to cover markets worldwide are available upon request.
- Various certificates covering worldwide usage are available. See 13. *Certificates* on page 22.

High reliability

- New state-of-the-art shaft seal design and materials offering these benefits:
 - high wear resistance and long operating life
 - improved sticking and dry-running capabilities.
- The pumps are less sensitive to impurities in the pumped liquid than similar pumps of the canned-rotor type.

Easy installation and commissioning

- A Quick Guide is supplied with each CMV pump, which enables easy installation and commissioning. Detailed multilingual installation and operating instructions are supplied with each pump.
- An installation indicator is fitted on three-phase pumps, which makes it easy to see if the electrical connection of the motor is correct. Based on the motor cooling air, it indicates the direction of rotation of the motor.

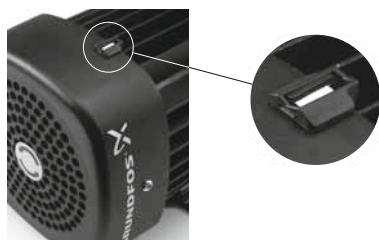

TM05 0870 1811

Fig. 6 Installation indicator

Service-friendly

- Service was in mind during the development.
- No special service tools required.
- Spare parts in stock for quick delivery.
- All parts available as kits, single parts or bulks.
- Service instructions and video make it simple to disassemble and assemble the pump.
- Service kit instructions available where estimated necessary.

Low noise level

The CMV pumps offer very silent operation.

High-performance hydraulics

Pump efficiency is maximised by the optimised hydraulics and carefully crafted production technology.

Electro-coated cast-iron parts

- Optimised corrosion resistance
- Better efficiency because of smooth surfaces.

Customised solutions

It is possible to create many different variants of the CMV pump.

For further information, see 20. *Customisation* on page 33.

- Motor adaptation.
- Pump body modifications.

Grundfos motor

Grundfos motors are remarkably silent and highly efficient.

Data and literature about the CMV pumps

All literature and technical data related to CMV pumps are available on line in Grundfos WebCAPS.

5. Identification

Type key

Example	CMV	3	-	8	A	-	R	-	A	-	E	-	A	V	B	E	F	-	A	-	A	-	N	-	X	-	X	
Type range CMV: Centrifugal Modular Vertical																												
Rated flow rate Rated flow rate at 50 Hz [m ³ /h]																												
Number of impellers																												
Pump version A: Basic version B: Oversize motor (one flange size larger) E: Pumps with certificates/approvals P: Undersize motor (one flange size smaller) T: Oversize motor (two flange sizes larger) BE: Oversize motor with certificates/approvals EP: Pumps with certificates/approvals and undersize motor ET: Pumps with certificates/approvals and double-oversize motor EX: Pumps with certificates/approvals and two other variants selected X: Special pump																												
Pipe connection C: Tri-Clamp® F: DIN, JIS or ANSI flange P: PJE/Victaulic® coupling R: Whitworth thread Rp (ISO 7/1) S: Internal NPT thread																												
Materials in contact with pumped liquids Suction and discharge parts EN-GJL-200 A: Pump shaft EN 1.4057/AISI 431 Impellers/chambers EN 1.4301/AISI 304 X: Special version																												
Rubber parts in pump (excl. neck ring and shaft seal) E: EPDM (ethylene propylene) V: FKM (flour) Note: Gaskets between chambers are always made of Tesnit® BA-U. In pumps with 8 impellers, the 3 uppermost gaskets between the chambers are replaced with O-rings. In pumps with 9 or 10 impellers, the 4 uppermost gaskets between the chambers are replaced with O-rings.																												
Shaft seal type designation A: O-ring seal with fixed driver																												
Material of rotating seal face Q: Silicon carbide (SiC) V: Aluminium oxide (Al2O3)																												
Terminal box position (degrees between inlet and outlet) 0 ° B: 90 ° C: 180 ° D: 240 °																												
Outlet position (degrees between inlet and outlet) 180 ° A: 0 ° B: 90 ° D: 240 °																												
Sensor Sensor designation																												
Mains plug A: Prepared for cable glands B: Harting® plug C: With cable D: Cable gland included																												
Motor information A: Standard motor (IP55) B: Phase-insulated motor for use with frequency converter C: Condensing environments D: Pt100 in stator E: Angular contact bearing F: Motor heater G: Three-phase motor with overload protection H: Single-phase motor with no protection J: Low-noise motor																												
Supply voltage A: 1 x 220 V, 60 Hz B: 1 x 115/230 V, 60 Hz C: 1 x 220-240 V, 50 Hz D: 1 x 127 V, 60 Hz E: 3 x 208-230/440-480 V, 60 Hz F: 3 x 220-240/380-415 V, 50 Hz G: 3 x 200/346 V, 50 Hz; 200-220/346-380 V, 60 Hz H: 3 x 575 V, 60 Hz I: 3 x 400 V, 50/60 Hz J: 3 x 380-415 V, 50 Hz; 440-480 V, 60 Hz O: 3 x 220-240/380-415 V, 50 Hz 3 x 220-255/380-440 V, 60 Hz																												
Material of secondary seal E: EPDM (ethylene propylene) V: FKM (flour)																												
Material of stationary seal face B: Carbon, synthetic resin-impregnated Q: Silicon carbide (SiC)																												

Note: The type key cannot be used for ordering as not all combinations are possible.

6. Product range

Pump type	Material	Shaft seal				Supply voltage [V]*	
		Cast iron, EN-GJL-200	AVBE	AVBV	AQQE	AQQV	Mains-operated motor
	1 x 220-240 V, 50 Hz (supply voltage C)						3 x 220-240 V/380-415 V, 50 Hz (supply voltage F)
CMV 3-2	•	•	•	•	•	•	•
CMV 3-3	•	•	•	•	•	•	•
CMV 3-4	•	•	•	•	•	•	•
CMV 3-5	•	•	•	•	•	•	•
CMV 3-6	•	•	•	•	•	•	•
CMV 3-7	•	•	•	•	•	•	•
CMV 3-8	•	•	•	•	•	•	•
CMV 3-9	•	•	•	•	•	•	•
CMV 3-10	•	•	•	•	•	•	•
CMV 5-2	•	•	•	•	•	•	•
CMV 5-3	•	•	•	•	•	•	•
CMV 5-4	•	•	•	•	•	•	•
CMV 5-5	•	•	•	•	•	•	•
CMV 5-6	•	•	•	•	•	•	•
CMV 5-7	•	•	•	•	•	•	•
CMV 5-8	•	•	•	•	•	•	•
CMV 5-9	•	•	•	•	•	•	•
CMV 5-10	•	•	•	•	•	•	•

* Other supply voltages are available on request.

7. Performance range

CMV, 50 Hz

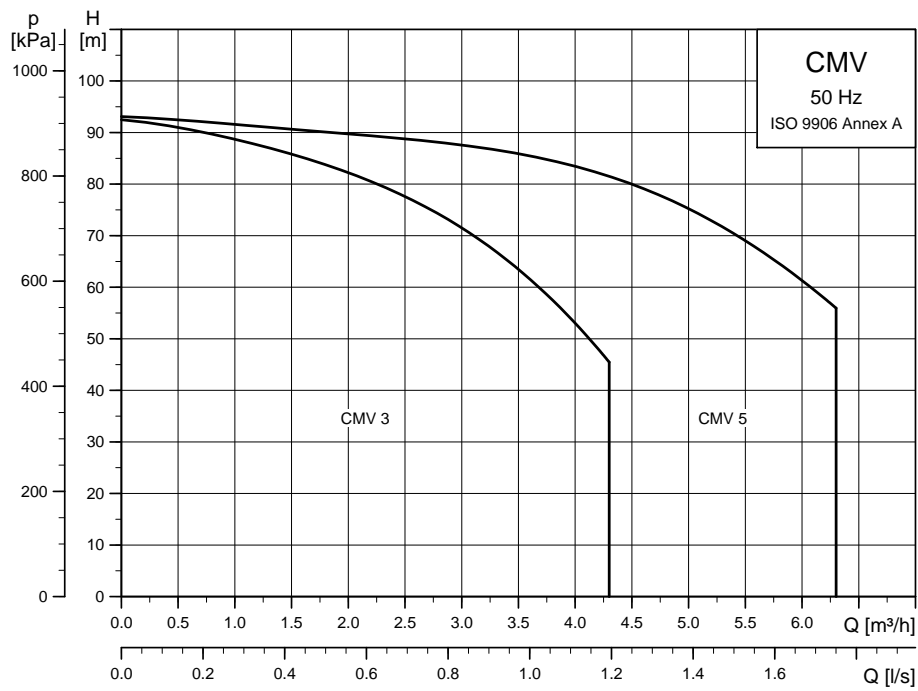

Fig. 7 Performance range

TM05 0779 1511

8. Operating conditions

Ambient temperature

Maximum ambient temperature in relation to liquid temperature

The maximum ambient temperature depends on the liquid temperature as shown in the table below.

Maximum ambient temperature	Liquid temperature
+55 °C	+90 °C

Storage and transport temperature

-50 °C to +70 °C.

Installation of pump

The pump must be installed with the motor shaft vertical. It must be mounted on a plane surface and secured by foundation bolts.

The pump should be installed so that the suction pipe is as short and the suction lift as small as possible.

The pump should be sited in a well ventilated but frost-free position.

The pump may be sited outdoors, but it should be protected from the elements by means of a suitable cover.

The pump should be installed with easy access for inspection, maintenance and service.

Maximum operating pressure and permissible liquid temperature

The maximum operating pressure and the permissible liquid temperature depend on the pump material, the type of shaft seal and the pumped liquid.

Shaft seal	Permissible liquid temperature ¹⁾	Maximum operating pressure
AVBx	-20 °C to +40 °C	10 bar
	+41 °C to +90 °C	6 bar
AQQx	-20 °C to +90 °C	10 bar

¹⁾ At liquid temperatures below 0 °C (32 °F), higher motor outputs may be required due to increased viscosity, for instance if glycol has been added to the water.

Operation in condensing environments

If the liquid temperature becomes lower than the ambient temperature, condensation may form in the motor during inactivity. In such cases, a motor suited for condensing environments must be used.

When installing CMV pumps outdoors, provide them with a suitable cover to protect them from build-up of condensed water.

Motors in outdoor installations radiate heat to and absorb heat from their surroundings. By day, a stopped motor will absorb more heat than it radiates; by night, especially clear nights, radiation from a stopped motor may be so high that the surface temperature falls a few degrees below the air temperature. This may cause the formation of condensation. Condensation on the inner surfaces may result in moisture on the electric components, including the printed-circuit boards, which means a risk of failure or even destruction of the motor.

Furthermore, the cover protects the motor against direct sunlight.

Environmental rating

All motors are IP55.

Operating range of the shaft seal

The operating range of the shaft seal depends on operating pressure, type of shaft seal and liquid temperature.

The curve in fig. 8 shows which shaft seals are suitable at a given temperature and a given pressure.

The curve applies to clean water.

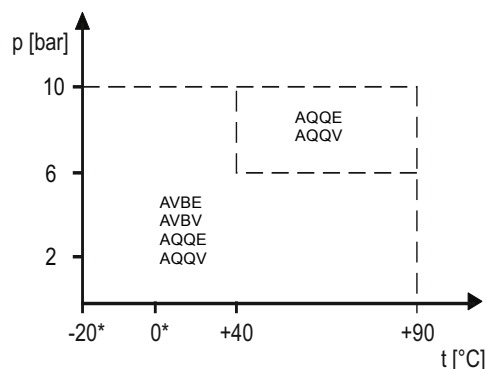

TM05 0728 1911

Fig. 8 Curve for the selection of shaft seals

* Antifreeze should be added at liquid temperatures below 0 °C.

Shaft seal run-in

The seal faces of the shaft seal are lubricated by the pumped liquid which means that a certain amount of leakage from the seal can be expected.

During the initial operating hours of the pump or when a new shaft seal is installed, a certain run-in period is required before the leakage is minimised. The amount of time required depends on the operating conditions, i.e. every time the operating conditions change, a new run-in period will basically be initiated.

Under normal conditions, the leaking liquid will evaporate. As a result, no leakage will be detected. However, some liquids, such as kerosene, will not evaporate. The leak will therefore appear as a shaft seal failure.

Viscosity

The pumping of liquids with densities or kinematic viscosities higher than those of water will cause a considerable pressure drop, a drop in the hydraulic performance and a rise in the power consumption.

For instance at liquid temperatures below 0 °C (32 °F), higher motor outputs may be required due to increased viscosity if glycol has been added to the water.

In such situations, the pump should be fitted with a larger motor. If in doubt, contact Grundfos or visit WebCAPS. See page 41.

Sound pressure level

The sound pressure values in the table below apply for CMV pumps. If the motor output (P_2) for a given CMV pump is not found in the table, use the nearest rounded-up value. The values for sound pressure include a tolerance of 3 dB(A) according to EN ISO 4871.

P_2 [kW]	50 Hz	60 Hz
	\bar{L}_{pA} [dB(A)]	\bar{L}_{pA} [dB(A)]
0.37	50	55
0.55	50	53
0.75	50	54
1.1	52	57
1.5	54	59
2.2	54	59
3.0	55	60
4.0	62	66
5.5	60	65
7.5	60	65
11.0	60	65

The audible noise from CMV pumps is primarily noise from the motor fan.

Minimum inlet pressure, NPSH

Calculation of the inlet pressure "H" is recommended in these situations:

- The liquid temperature is high.
- The flow is significantly higher than the rated flow.
- Water is drawn from depths.
- Water is drawn through long pipes.
- Inlet conditions are poor.

To avoid cavitation, make sure that there is a minimum pressure on the suction side of the pump. The maximum suction lift "H" in metres head can be calculated as follows:

$$H = p_b \times 10.2 - \text{NPSH} - H_f - H_v - H_s$$

p_b	=	Barometric pressure in bar. (Barometric pressure can be set to 1 bar). In closed systems, p_b indicates the system pressure in bar.
NPSH	=	Net Positive Suction Head in metres head. (To be read from the NPSH curve at the highest flow the pump will be delivering).
H_f	=	Friction loss in suction pipe in metres head. (At the highest flow the pump will be delivering).
H_v	=	Vapour pressure in metres head. (To be read from the vapour pressure scale, " H_v " depends on the liquid temperature " T_m ").
H_s	=	Safety margin = minimum 0.5 metres head.

If the "H" calculated is positive, the pump can operate at a suction lift of maximum "H" metres head.

If the "H" calculated is negative, an inlet pressure of minimum "H" metres head is required.

Note: To avoid cavitation, **never** select a pump with a duty point too far to the right on the NPSH curve.

Always check the NPSH value of the pump at the highest possible flow.

9. Pumped liquids

Thin, non-explosive liquids, not containing solid particles or fibres. The liquid must not chemically attack the pump materials.

When pumping liquids with a density and/or viscosity higher than those of water, oversized motors must be used, if required.

Whether a pump is suitable for a particular liquid depends on a number of factors of which the most important are the chloride content, pH value, temperature and content of chemicals and oils.

Please note that aggressive liquids (for instance seawater and some acids) may attack or dissolve the protective oxide film of the stainless steel and thus cause corrosion.

List of pumped liquids

A number of typical liquids are listed below.

Other pump versions may be applicable, but those stated in the list are considered to be the best choices.

The table is intended as a general guide only and cannot replace actual testing of the pumped liquids and pump materials under specific working conditions.

The list should, however, be applied with some caution as factors such as concentration of the pumped liquid, liquid temperature or pressure may affect the chemical resistance of a specific pump version.

Safety precautions must be taken when pumping dangerous liquids.

Notes

a	To minimise the risk of corrosion the pump must be running continuously, i.e. standstills must not exceed 6 to 8 hours.
b	May contain additives or impurities which can cause shaft seal problems.
c	The density and viscosity may differ from those of water. Consider this when calculating motor and pump performance.
d	In order to avoid corrosion, the liquid must be free of oxygen.
e	Flammable or combustible liquid. Safety precautions must be considered to ensure safe handling of flammable liquids. Handling the liquid above the flash point and/or boiling point will require the greatest restrictions. A seal-less pump may be required. Contact Grundfos.
f	Risk of crystallisation/precipitation on the shaft seal.
g	If oil residues are present, EPDM cannot be used.
h	As no protective deposits are formed in demineralised water, a slight increase in the corrosion rate is to be expected. If impurities (e.g. contamination with metal ions) in the pumped liquid are unacceptable, cast iron or copper containing metals should not be used. If the CO ₂ content is high, cast iron is unsuitable for use.
i	Special conditions related to the properties of demineralised water with a conductivity less than 2 microS/cm makes a SiC/SiC shaft seal unsuitable for use. Use the ceramic/carbon shaft seal combination instead.

Pumped liquids	Chemical formula	Notes	Additional information	Cast iron (EN-GJL-200)
Water				
Boiler feed water				AVBE/AQQE
Condensate				AVBE/AQQE
Cooling and cutting lubricant		b		AQQV
Groundwater			< 300 ppm chloride	AVBE/AQQE
Demineralised water		h	> 2 microS/cm	AQQE
Demineralised water		h, i	< 2 microS/cm	AVBE
District heating water				AVBE/AQQE
Oil-containing water				AVBV/AQQV
Softened water				AVBE/AQQE
Coolants				
Ethylene glycol	C ₂ H ₄ (OH) ₂	b, c		AQQE
Glycerine (glycerol)	C ₃ H ₅ (OH) ₃	b, c		AQQE
Hydrocarbon-based coolant		c, e		AQQV
Potassium acetate (inhibited)	CH ₃ COOK	b, c, d, f		AQQE
Potassium formate (inhibited)	HCOOK	b, c, d, f		AQQE
Propylene glycol	CH ₃ CHOHCH ₂ OH	b, c		AQQE
Fuels				
Diesel oil		e		AVBV/AQQV
Jet fuel		e		AVBV/AQQV
Kerosene		e		AVBV/AQQV
Naphta		e		AVBV/AQQV
Petrol		e		AVBV/AQQV
Biodiesel		e		AVBV/AQQV
Mineral oils				
Crude oil		b, c, e	< 20 °C	AQQV
Mineral lubricating oil		c, e		AVBV/AQQV
Mineral motor oil		c, e		AVBV/AQQV
Synthetic oils				
Synthetic lubricating oil		c, e		AVBV/AQQV
Synthetic motor oil		c, e		AVBV/AQQV
Silicone oil		c		AVBV/AQQV
Vegetable oils				
Corn oil		b, c		AVBV/AQQV
Olive oil		b, c		AVBV/AQQV
Peanut oil		b, c		AVBV/AQQV
Rapeseed oil		b, c		AVBV/AQQV
Soy oil		b, c		AVBV/AQQV
Cleaning				
Alkaline degreasing agent		b, g		AQQE
Soap (salts of fatty acids)		b	< 80 °C	AQQV
Organic solvents				
Acetone	C ₃ H ₆ O	e		AVBE/AQQE
Ethyl alcohol (ethanol)	C ₂ H ₆ O	e		AVBE/AQQE
Isopropyl alcohol	C ₃ H ₇ OH	e		AVBE/AQQE
Methyl alcohol (methanol)	CH ₃ OH	e		AVBE/AQQE

Pumped liquids	Chemical formula	Notes	Additional information	Cast iron (EN-GJL-200)
Salts				
Ammonium bicarbonate	NH_4HCO_3	b, c	20 °C, 15 %	AQQE
Potassium bicarbonate	KHCO_3	b, c	20 °C, 20 %	AQQE/AQQV
Sodium carbonate	Na_2CO_3	b, c, f	20 °C, 20 %	AQQE
Sodium nitrate	NaNO_3	b, c	20 °C, 5 %	AQQE/AQQV
Sodium nitrite	NaNO_2	b, c	20 °C, 20 %	AQQE/AQQV
Sodium phosphate (di)	Na_2HPO_4	b, c, f	30 °C, 30 %	AQQE/AQQV
Sodium phosphate (tri)	Na_3PO_4	b, c, f	20 °C, 10 %	AQQE/AQQV
Sodium sulphite	Na_2SO_3	b, c, f	20 °C, 1 %	AQQE/AQQV
Alkalies				
Ammonium hydroxide	NH_4OH		30 °C, 30 %	AQQE
Calcium hydroxide	Ca(OH)_2	b	30 °C, 5 %	AQQE
Potassium hydroxide	KOH	c, f	20 °C, 20 %	AQQE
Sodium hydroxide	NaOH	c, f	20 °C, 20 %	AQQE

10. Construction

Pump

The CMV pumps are non-self-priming, vertical, multistage centrifugal pumps. The pumps have a radial suction port in the bottom part and radial discharge port in the top part.

All movable parts are made of stainless steel.

All pumps incorporate a maintenance-free mechanical O-ring shaft seal with fixed driver.



TM05 0727 1511

Fig. 9 CMV pumps

Motor

CMV pumps are fitted with totally enclosed, fan-cooled, 2-pole motors with principal dimensions to EN 50347.

Electrical tolerances comply with EN 60034.

Electrical data

Insulation class	F
Enclosure class	IP55*
Supply voltages (tolerance $\pm 10\%$)	1 x 220-240 V, 50 Hz 3 x 220-240/380-415 V, 50 Hz

* IP55 is not recommended for operation in condensing environments. For operation in such environments, see *Operation in condensing environments* on page 11.

High-efficiency motors

CMV motors comply with the MEPS requirements in different parts of the world, for example the EuP directive in the EU and KEMCO in Korea.

This means that CMV motors as minimum are living up to IE2 efficiency levels. IE3 motors are available on request. Please contact Grundfos.

Motor protection

Mains-operated motors (CMV)

Single-phase motors, 1 x 115/230 V, 60 Hz*, do not incorporate motor protection and must be connected to a motor-protective circuit breaker which can be manually reset. Set the motor-protective circuit breaker according to the rated current of the motor ($I_{1/1}$). See nameplate.

* 60 Hz supply voltages are available on request.

Other single-phase motors have built-in current- and temperature-dependent motor protection in accordance with IEC 60034-11 and require no further motor protection. The motor protection is of the TP 211 type, which reacts to both slow- and quick-rising temperatures. The motor protection is automatically reset.

Three-phase motors must be connected to a motor-protective circuit breaker which can be manually reset. Set the motor-protective circuit breaker according to the rated current of the motor ($I_{1/1}$). See nameplate.

Frequency converter operation

All three-phase motors can be connected to a frequency converter. Depending on the frequency converter type, this may cause increased acoustic noise from the motor. Furthermore, it may cause the motor to be exposed to detrimental voltage peaks.

As standard MG 71- and MG 80-based motors have no phase insulation and must therefore be protected against voltage peaks higher than 650 V (peak value) between the supply terminals.

Note: MG 71- and MG 80-based motors with phase insulation are available on request.

The above disturbances, i.e. both increased acoustic noise and detrimental voltage peaks, can be eliminated by fitting an LC filter between the frequency converter and the motor.

For further information, please contact the frequency converter supplier or Grundfos.

Shaft seal

The shaft seal for the CMV pumps is of the O-ring type, which makes it very flexible when different types of O-rings and seal-face materials are required. The shaft seal has a fixed seal driver which ensures a reliable rotation of all parts, even under the most extreme operating conditions.

Due to the special design of the shaft seal and the interfaces to the rest of the pump construction, the dry-running capabilities are improved significantly compared to most other similar shaft seals and pump types. Furthermore, improvements have been made to reduce the risk and effect of sticking. The shaft seal types available can be found in *Selection of shaft seal* on page 25 where the key parameters of selecting a shaft seal are also described.



TM04 3933 0409

Fig. 10 Exploded view of shaft seal

Note: The available shaft seals for CMV pumps are very robust and durable, but dry running must always be avoided.

Details regarding operating conditions for the shaft seal can be found in *Operating range of the shaft seal* on page 11.

Further information about the shaft seal can be found in the separate data booklet covering shaft seals which can be downloaded from WebCAPS.

See 22. *Further product documentation* on page 41.

Title	Publication number
Shaft seals	96519875

CMV 5

Sectional drawing

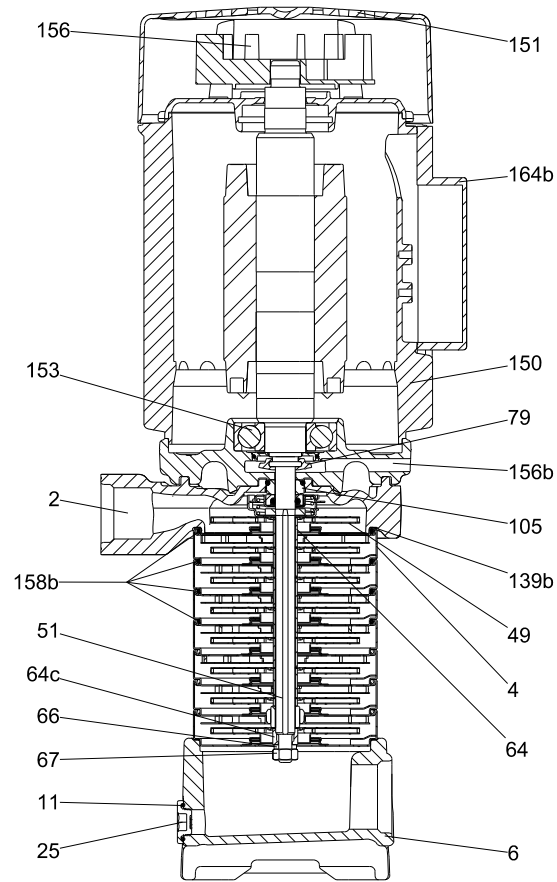

TM05 0852 1611

Fig. 11 CMV 5-8 with MG90SA motor

Components

Pos.	Component	Pos.	Component	Pos.	Component
2	Discharge part	64c	Clamp	153	Ball bearing
4	Chamber	66	Washer (NORD-LOCK®)	156	Fan
6	Inlet part	67	Nut	156b	Motor flange
11	O-ring	79	Diverting disc	158b	O-ring
25	Plug	105	Shaft seal	164b	Terminal box
49	Impeller	139b	Gasket		
51	Pump shaft	150	Stator housing		
64	Spacing pipe	151	Fan cover		

Material specification

Pos.	Description	Material	DIN	ISO/AISI/ASTM
Motor parts				
156b	Motor flange	Cast iron		
150	Stator housing	Silumin (Alu)		
151	Fan cover	Composite PBT/PC		
153	Ball bearing			
156	Fan	Composite PA 66 30 % GF		
164b	Terminal box, MG	Composite PC/ASA or silumin (Alu)		
79	Diverting disc	Silicone fluid (LSR)		
Pump parts				
105	Shaft seal, steel parts	Stainless steel	1.4301	AISI 304
	Shaft seal, seal faces	Al ₂ O ₃ /carbon or SiC		
51	Pump shaft	Stainless steel	1.4057	AISI 431
11 158b ²⁾	O-rings	EPDM or FKM		
139b	Gasket	Aramide fibres (nbr)		
2	Discharge part	Cast iron		
6	Inlet part	Cast iron		
4	Chamber	Stainless steel	1.4301	AISI 304
25	Plug	Stainless steel	1.4404	AISI 316L
49	Impeller	Stainless steel	1.4301	AISI 304
64	Spacing pipe	Stainless steel	1.4401	AISI 316
64c	Clamp	Stainless steel	STX2000 ¹⁾	
67	Nut	Stainless steel A4		
66	Washer (NORD-LOCK®)	Steel	1.4547	

1) STX2000 ~ CrNiMO 22 19 4.

2) Only in CMV pumps with seven or more stages.

11. Grundfos CUE

CMV pumps connected to Grundfos CUE frequency converters



Fig. 12 Grundfos CUE product range

Grundfos CUE is a complete range of frequency converters for pump control in a wide range of applications. Grundfos CUE is designed for wall mounting.

Grundfos CUE provides a variety of benefits to the end-user.

The benefits include

- Grundfos E-pump functionality and user interface
- application- and pump family-related functions
- increased comfort compared to mains-operated pump solutions
- simple installation and commissioning compared to standard frequency converters.

GrA 4404

Functions

Intuitive start-up guide

The start-up guide enables easy installation and commissioning as well as plug-and-pump convenience. Few settings need to be made by the installer as the rest is done automatically or preset from the factory.

Smart user interface



Fig. 13 Grundfos CUE control panel

Grundfos CUE features a unique user-friendly control panel with graphic display and easy-to-use buttons. Panel layout resembles the well-known Grundfos R100 remote control, which is used with Grundfos E-pumps.

TM04 3283 4108

Controlling the value you choose

Grundfos CUE has a built-in PI controller offering closed-loop control of a desired value.

The values include

- constant differential pressure
- proportional pressure
- constant temperature
- constant flow.

Wide product range

The CUE product range is quite comprehensive, covering five different voltage ranges, enclosure classes IP20/21 (Nema 1) and IP54/55 (Nema 12), and a wide range of output powers.

The table below provides a general overview.

Input voltage [V]	Output voltage [V]	Motor [kW]
1 x 200-240	3 x 200-240	1.1 - 7.5
3 x 200-240	3 x 200-240	0.75 - 45
3 x 380-500	3 x 380-500	0.55 - 250
3 x 525-600	3 x 525-600	0.75 - 7.5

12. Approvals and markings

Approvals

CB certificate, IEC countries.

C-tick mark, New Zealand and Australian EMC.

EC declaration of conformity

- Machinery Directive (2006/42/EC).
 - Standards used:
 - EN 809: 2008 and EN 60204-1: 2006.
- Low Voltage Directive (2006/95/EC).
 - Applicable when the rated power is lower than 2.2 kW.
 - Standards used:
 - EN 60335-1: 2002 and EN 60335-2-51: 2003.
- EMC Directive (2004/108/EC).

Other approvals and compliance with directives

- GOST (Russia)
- Compliance with RoHS, directive 2002/96/EC
- KEMCO.

Drinking water approvals

- ACS.

Markings

C-tick mark



Fig. 14 C-tick mark

CE mark



Fig. 15 CE mark

TM03 3091 0206

TM02 1695 1901

13. Certificates

Certificate	Description
Certificate of compliance with the order	According to EN 10204, 2.1. Grundfos document certifying that the pump supplied is in compliance with the order specifications.
Test certificate. Non-specific inspection and testing	According to EN 10204, 2.2. Certificate with inspection and test results of a non-specific pump.
Inspection certificate 3.1	Grundfos document certifying that the pump supplied is in compliance with the order specifications. Inspection and test results are mentioned in the certificate.
Inspection certificate	<p>Grundfos document certifying that the pump supplied is in compliance with the order specifications. Inspection and test results are mentioned in the certificate. Certificate from the surveyor is included.</p> <p>We offer the following inspection certificates:</p> <ul style="list-style-type: none"> • Lloyds Register of Shipping (LRS) • Det Norske Veritas (DNV) • Germanischer Lloyd (GL) • Bureau Veritas (BV) • American Bureau of Shipping (ABS) • Registro Italiano Navale Agenture (RINA) • China Classification Society (CCS) • Russian maritime register of Shipping (RS) • Biro Klassifikasio Indonesia (BKI) • United States Coast Guard (USCG) • Nippon Kaiji Koykai (NKK)
Vibration report	Vibration report indicating the values measured during the performance test of the specific pump according to ISO 10816.
Motor test report	Shows the performance test of the specific motor, including power output, current, temperature, stator windings resistance and insulation test.
Cleaned and dried pump	Confirms that the specific pump has been cleaned and dried, and how it was done.
Electro-polished pump	Confirms that the specific pump has been electro-polished. The maximum surface roughness is specified in the report.

Examples of the certificates are shown on pages 23.

Note: Other certificates are available on request.

Examples of certificates

Certificate of compliance with the order

BE THINK INNOVATE		GRUNDFOS	
Certificate of compliance with the order			
EN 10204 2.1			
Customer name			
Customer order no.			
Customer Tag no.			
GRUNDFOS order no.			
Product type			
<p>We the undersigned hereby guarantee and certify that the materials and/or parts for the above mentioned product were manufactured, tested, inspected, and conform to the full requirements of the appropriate catalogues, drawings and/or specifications relative thereto.</p>			
GRUNDFOS Date: _____ Signature: _____ Name: _____ Dept.: _____			
Part no. 96 50 78 95/1001002			

TM03 4165 1706

Test certificate

BE THINK INNOVATE		GRUNDFOS	
Test certificate			
Non-specific inspection and testing			
EN 10204 2.2			
Customer name			
Customer order no.			
Customer TAG no.			
GRUNDFOS order no.			
Pump			
Pump type		Part number	
Motor make		Part number	
Flow	m ³ /h		
Head	m		
Power P2	kW		
Voltage	V		
Frequency	Hz		
Full load current	A		
Motor speed	min ⁻¹		
<p>We the undersigned hereby guarantee and certify that the materials and/or parts for the above mentioned product were manufactured, tested, inspected, and conform to the full requirements of the appropriate catalogues, drawings and / or specifications relative thereto.</p>			
GRUNDFOS Date: _____ Signature: _____ Name: _____ Dept.: _____			
Part no. 96 50 78 96/1001002			

TM03 4163 1706

Inspection certificate 3.1

BE THINK INNOVATE		GRUNDFOS	
Inspection certificate.			
EN 10204 3.1			
Manufactured by			
GRUNDFOS order no.			
GRUNDFOS DUT id.			
Customer order no.			
Customer name and address			
Shipyard / factory			
Ship / new building			
Customer TAG no.			
Classifying society	GRUNDFOS authorized department		
Pump		Motor	
Pump type		Make	
Part number		Part number	
Serial no.		Serial No.	
Flow rate (m ³ /h)		P2 (kW)	
Head (m)		Voltage (V)	
Max. ope. P/t (bar / °C)		Current (A)	
	Din / W. - No.	n(min ⁻¹)	
Base/Pump head cover		Frequency (Hz)	
Impeller/guide vanes		Insulation class	
Shaft/sleeve		Power factor	
Customer's requirements			
Flow rate (m ³ /h)		Head (m)	
Test result ref. requirements			
Q(m ³ /h)	H(m)	n(min ⁻¹)	I(A) P1(kW)
Hydrostatic test Bar – no leaks or deformation observed			
GRUNDFOS Date: _____ Signature: _____ Name: _____ Dept.: _____			
Part no. 96 50 78 97/1034142			

TM03 4162 3607

Inspection certificate

BE THINK INNOVATE		GRUNDFOS	
Inspection certificate.			
Russian Maritime Register of Shipping			
Manufactured by			
GRUNDFOS order no.			
GRUNDFOS DUT id.			
Customer order no.			
Customer name and address			
Shipyard / factory			
Ship / new building			
Customer TAG no.			
Classifying society	Russian Maritime Register of Shipping (RS)		
Pump		Motor	
Pump type		Make	
Part number		Part number	
Serial no.		Serial No.	
Flow rate (m ³ /h)		P2 (kW)	
Head (m)		Voltage (V)	
Max. ope. P/t (bar / °C)		Current (A)	
Service		n(min ⁻¹)	
Medium		Frequency (Hz)	
	Din / W. - No.	Insulation class	
Base/Pump head cover		Power factor	
Impeller/guide vanes			
Shaft/sleeve			
Customer's requirements			
Flow rate (m ³ /h)		Head (m)	
Test result ref. requirements			
Q(m ³ /h)	H(m)	n(min ⁻¹)	I(A) P1(kW)
Hydrostatic test Bar – no leaks or deformation observed			
The pump has been marked			
Surveyor signature: _____		GRUNDFOS	
Tested date: _____		Date: _____	
		Signature: _____	
		Name: _____	
		Dept.: _____	
Part no. 96 50 79 25/1014142			

TM03 4156 3607

14. Selection and sizing

Selection of pumps

Selection of pumps should be based on these elements:

- the duty point of the pump (see below)
- dimensional data such as pressure loss as a result of height differences, friction loss in the pipework, pump efficiency, etc. (see below)
- pump materials (see page 25)
- pump connections (see page 25)
- shaft seal (see page 25).

Duty point of the pump

From a duty point it is possible to select a pump on the basis of the curve charts starting on page 27.

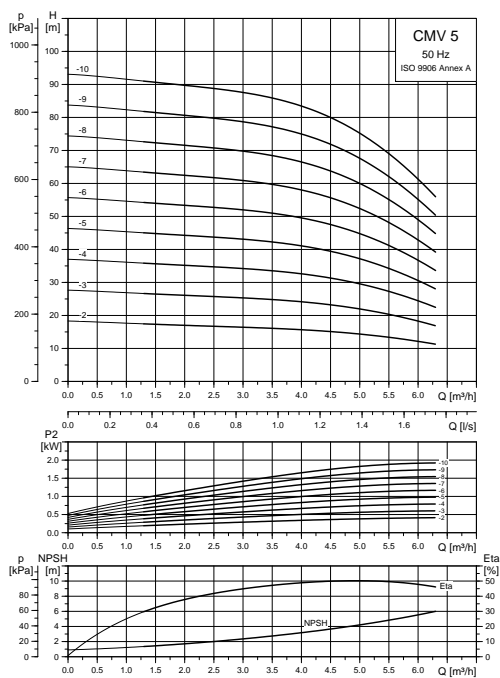

Fig. 16 Example of a curve chart

Dimensional data

When sizing a pump, take the following factors into account:

- Required flow and pressure at the draw-off point.
- Pressure loss as a result of height differences (H_{geo}).
- Friction loss in the pipework (H_f).
It may be necessary to account for pressure loss in connection with long pipes, bends or valves, etc.
- Best efficiency at the estimated duty point.
- NPSH value.
For calculation of the NPSH value, see *Minimum inlet pressure, NPSH* on page 12.

Pump efficiency

When sizing the pump, the efficiency (η) should be considered so that the pump will operate at or near its maximum efficiency, for instance on the right-hand side in the curve example in fig. 17.

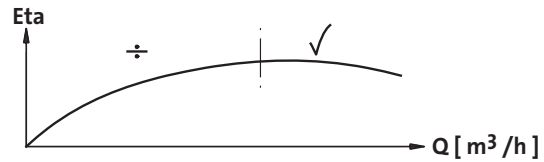

Fig. 17 Best efficiency

Before determining the best efficiency point, the operation pattern of the pump needs to be identified. If the pump is expected to operate at the same duty point, then select a CMV pump which is operating at a duty point corresponding with the best efficiency of the pump. The example in fig. 18 shows how to check the pump efficiency when selecting a CMV pump.

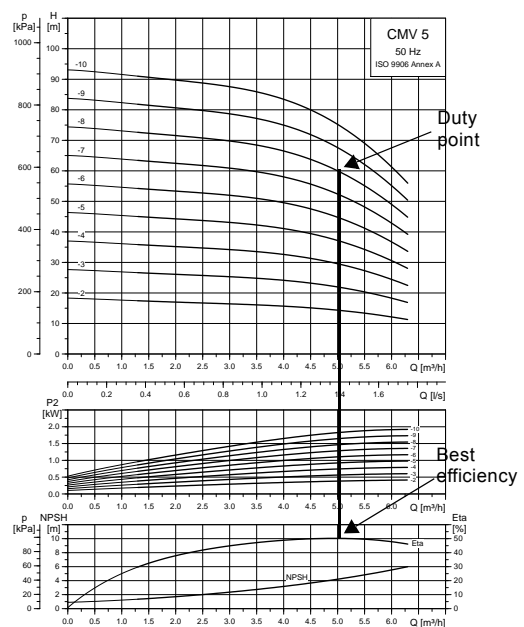

Fig. 18 Example of a CMV pump's duty point

Pump materials

Select the material variant on the basis of the liquid to be pumped. The table below gives a general recommendation regarding selection of pump material.

Liquid to be pumped	Material in contact with pumped liquid	Pump type
Clean, non-aggressive liquids such as potable water and oils	Cast iron* (EN-GJL-200)	CMV-A

* The impeller, chamber and filling plugs are made of stainless steel (EN 1.4301/AISI 304).
The pump shaft is made of stainless steel (EN 1.4057/AISI 431).

For more specific selection based on the pumped liquid, see *List of pumped liquids* on page 13, or contact Grundfos.

Pump connections

Selection of pump connection depends on the rated pressure and pipework. To meet any requirement, the CMV pumps offer a wide range of flexible connections such as:

- Tri-Clamp®
- DIN/ANSI/JIS flange
- PJE/Victaulic® coupling
- Whitworth thread Rp
- Internal NPT thread.

Selection of shaft seal

As standard, the CMV pumps are fitted with a Grundfos O-ring type shaft seal with fixed driver suitable for the most common applications.



TM04 3934 0409

Fig. 19 Shaft seal (O-ring type with fixed driver)

The table below shows the available shaft seal types for CMV pumps.

Pump type	Shaft seal type	Material	Rubber parts
CMV	AQQE AQQV AVBE AVBV	Stainless steel	EPDM (E) FKM (V)

These key parameters must be taken into account when selecting the shaft seal:

- type of pumped liquid
- liquid temperature
- maximum pressure.

Use the curve in fig. 8 on page 11 to select a suitable shaft seal. If the pumped liquid differs from water, a suitable shaft seal can be found in *List of pumped liquids* on pages 13 to 15.

Note: The list should be applied with some caution, as factors such as concentration of the pumped liquid, liquid temperature or pressure may affect the chemical resistance of a specific pump version.

15. How to read the curve charts

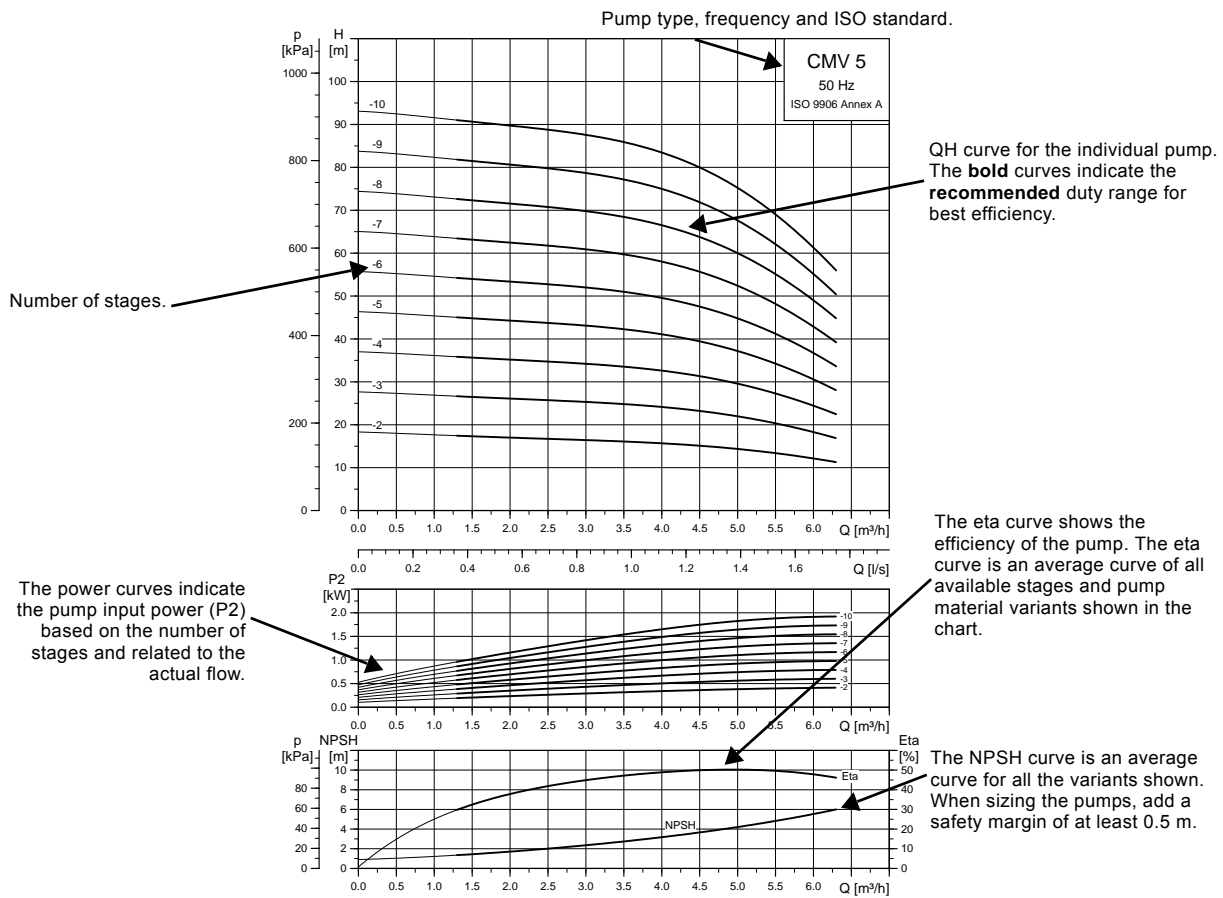

TM05 0727 1511

Fig. 20 How to read the curve charts

Guidelines to performance curves

The guidelines below apply to the curves shown on the following pages:

- Tolerances to ISO 9906, Annex A, if indicated.
- Measurements have been made with airless water at a temperature of +20 °C.
- The curves apply to the following kinematic viscosity: $\mu = 1 \text{ mm}^2/\text{s}$ (1 cSt).
- The QH curves apply to fixed speeds of 2900 min^{-1} (50 Hz).
Note: Please refer to WebCAPS for pump curves which include the characteristic of the selected motor. In WebCAPS, it is also possible to adjust the curves depending on the density and viscosity.
- The conversion between head H (m) and pressure p (kPa) applies to a water density of $\rho = 1000 \text{ kg/m}^3$.

- Due to the risk of overheating, the pumps should not be used at a flow below the minimum flow rate. The curve in fig. 21 shows the minimum flow rate as a percentage of the rated flow rate in relation to the liquid temperature.

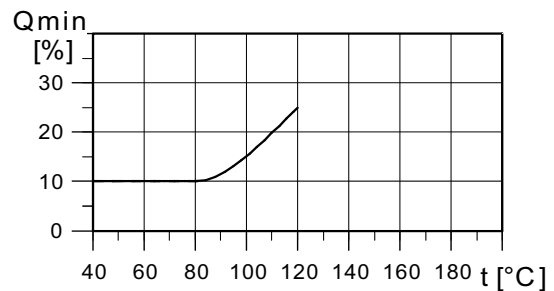
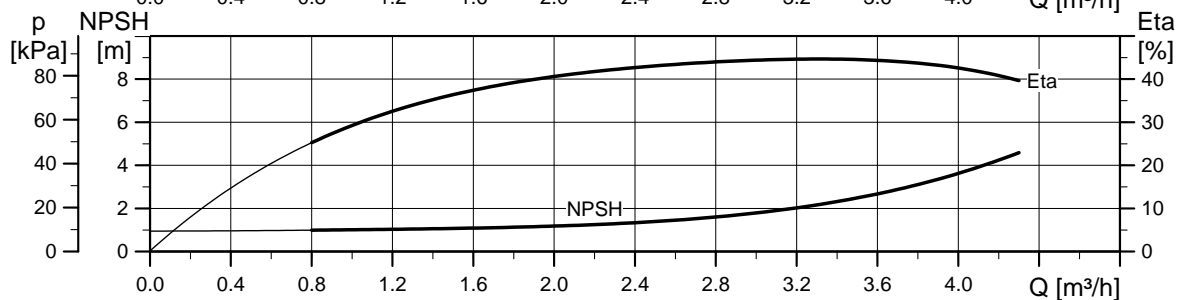
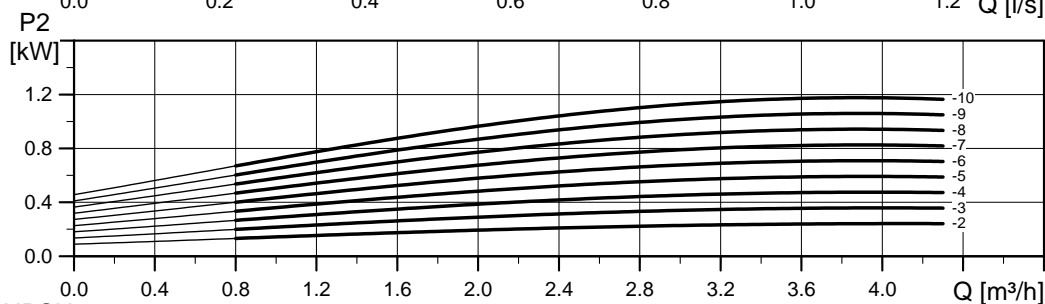
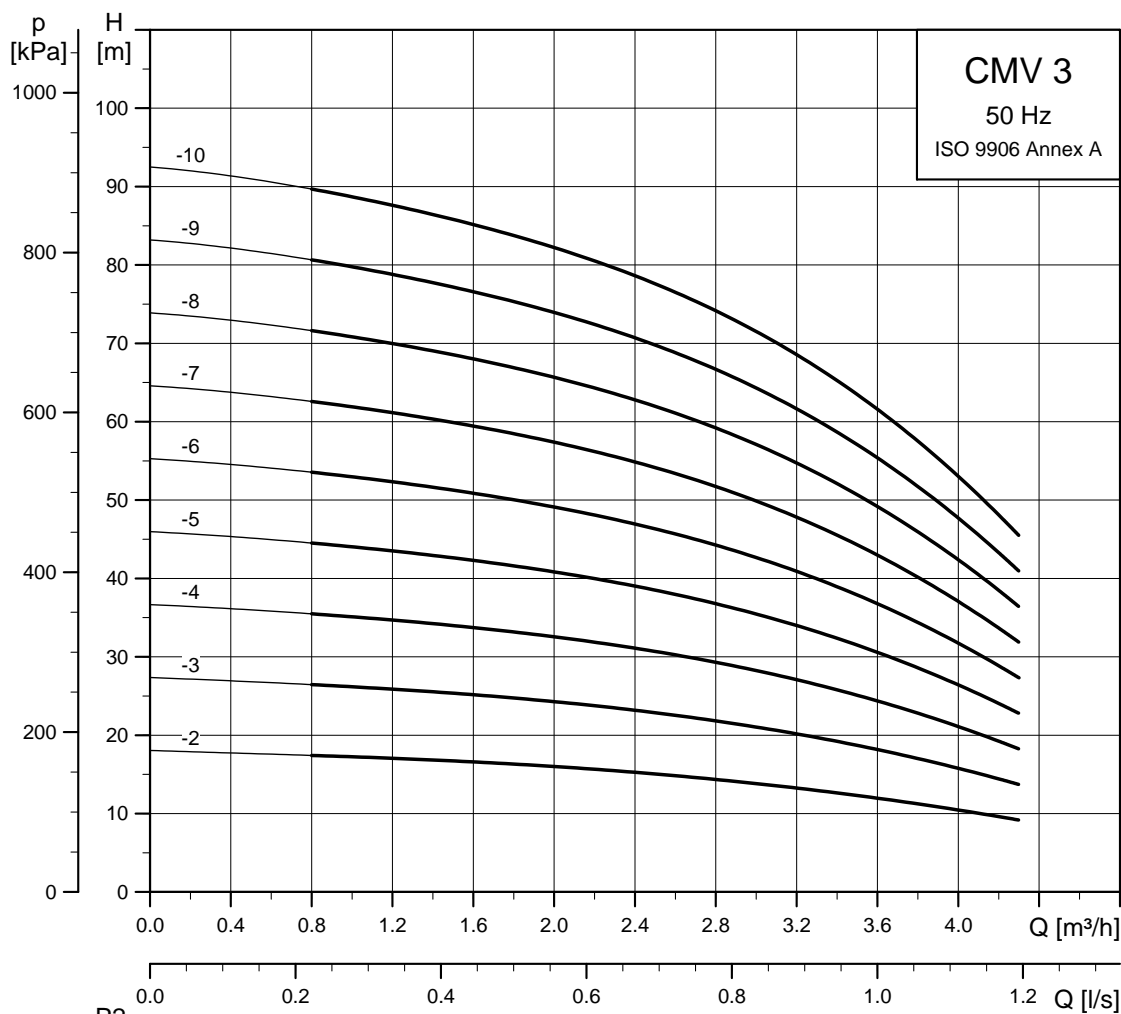

Fig. 21 Minimum flow rate

TM04 3791 5005

16. Performance curves, CMV, 50 Hz

CMV 3



TM05 0730 1511

CMV 5

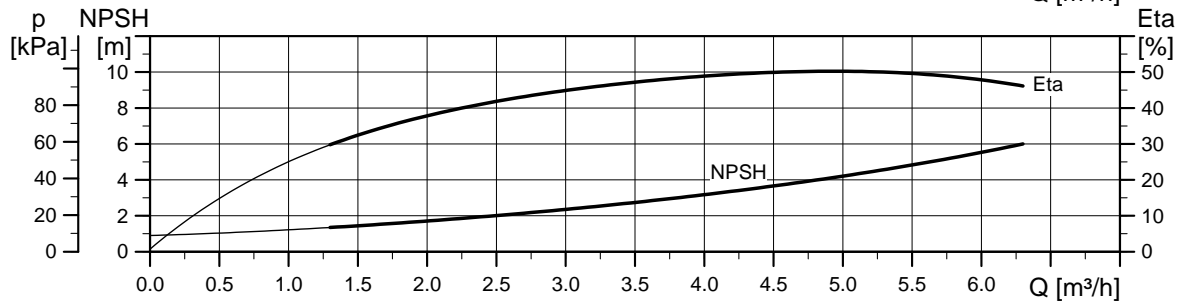
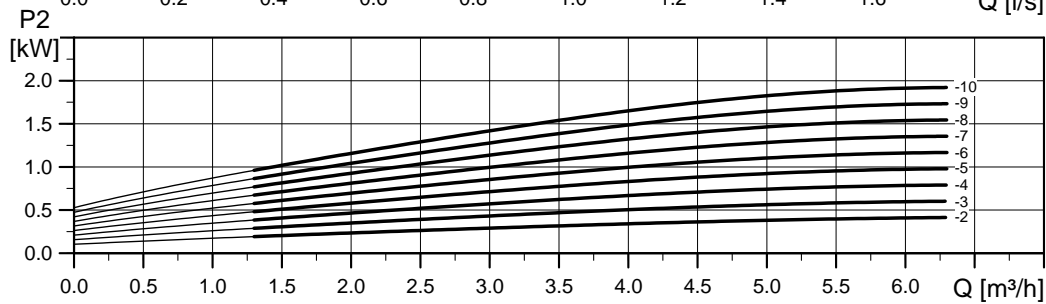
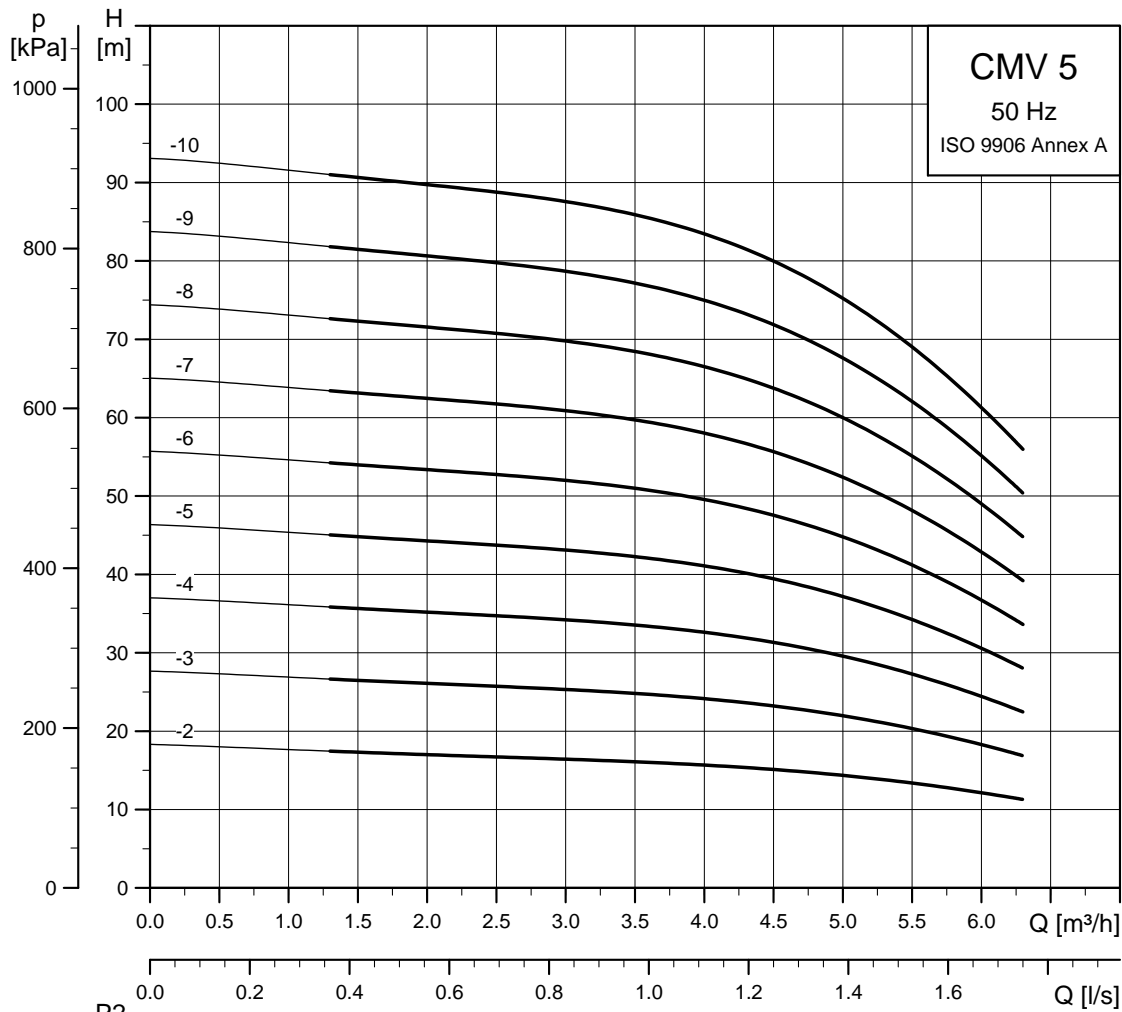

TM05 0731 1511

17. Dimensions, CMV 50 Hz

CMV 3

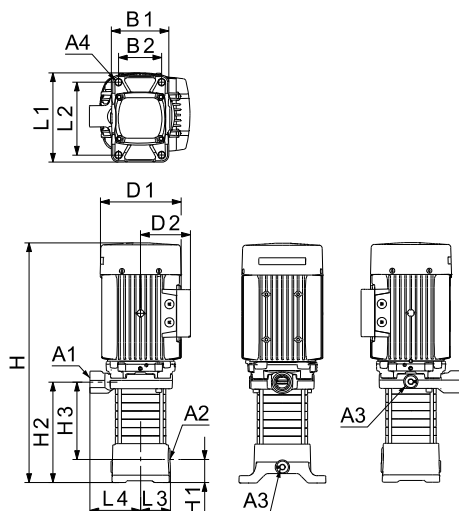

TMO5 0851 1611

Dimensions

1 x 220-240 V, 50 Hz (supply voltage C)

Pump type	Frame size	P2 [kW]	Dimensions															
			A1	A2	A3	A4	H	H1	H2	H3	B1	B2	D1	D2	L1	L2	L3	L4
CMV 3-4	71B	0.5	Rp 1	Rp 1	Rp 3/8	14.0	362.9	50	161.2	111.2	126.0	95.0	142.0	133.0	191.0	160.0	65.0	73.5
CMV 3-5	71B	0.5	Rp 1	Rp 1	Rp 3/8	14.0	381.0	50	179.3	129.3	126.0	95.0	142.0	133.0	191.0	160.0	65.0	73.5
CMV 3-6	80A	0.67	Rp 1	Rp 1	Rp 3/8	14.0	439.1	50	197.4	147.4	126.0	95.0	142.0	133.0	191.0	160.0	65.0	73.5
CMV 3-7	80B	0.9	Rp 1	Rp 1	Rp 3/8	14.0	457.2	50	215.5	165.5	126.0	95.0	142.0	133.0	191.0	160.0	65.0	73.5
CMV 3-8	80B	0.9	Rp 1	Rp 1	Rp 3/8	14.0	475.3	50	233.6	183.6	126.0	95.0	142.0	133.0	191.0	160.0	65.0	73.5
CMV 3-9	90SA	1.3	Rp 1	Rp 1	Rp 3/8	14.0	545.0	50	238.4	188.4	126.0	95.0	178.0	139.0	191.0	160.0	65.0	111.0
CMV 3-10	90SA	1.3	Rp 1	Rp 1	Rp 3/8	14.0	563.1	50	256.5	206.5	126.0	95.0	178.0	139.0	191.0	160.0	65.0	111.0

3 x 220-240 V / 380-415 V, 50 Hz (supply voltage F)

Pump type	Frame size	P2 [kW]	Dimensions															
			A1	A2	A3	A4	H	H1	H2	H3	B1	B2	D1	D2	L1	L2	L3	L4
CMV 3-2	71A	0.46	Rp 1	Rp 1	Rp 3/8	14.0	326.7	50	125.0	75.0	126.0	95.0	142.0	109.0	191.0	160.0	65.0	73.5
CMV 3-3	71A	0.46	Rp 1	Rp 1	Rp 3/8	14.0	344.8	50	143.1	93.1	126.0	95.0	142.0	109.0	191.0	160.0	65.0	73.5
CMV 3-4	71A	0.46	Rp 1	Rp 1	Rp 3/8	14.0	362.9	50	161.2	111.2	126.0	95.0	142.0	109.0	191.0	160.0	65.0	73.5
CMV 3-5	71B	0.65	Rp 1	Rp 1	Rp 3/8	14.0	381.0	50	179.3	129.3	126.0	95.0	142.0	109.0	191.0	160.0	65.0	73.5
CMV 3-6	71B	0.65	Rp 1	Rp 1	Rp 3/8	14.0	399.1	50	197.4	147.4	126.0	95.0	142.0	109.0	191.0	160.0	65.0	73.5
CMV 3-7	80A	0.84	Rp 1	Rp 1	Rp 3/8	14.0	457.2	50	215.5	165.5	126.0	95.0	142.0	109.0	191.0	160.0	65.0	73.5
CMV 3-8	80B	1.2	Rp 1	Rp 1	Rp 3/8	14.0	495.3	50	233.6	183.6	126.0	95.0	142.0	109.0	191.0	160.0	65.0	73.5
CMV 3-9	80B	1.20	Rp 1	Rp 1	Rp 3/8	14.0	513.4	50	251.7	201.7	126.0	95.0	142.0	109.0	191.0	160.0	65.0	73.5
CMV 3-10	80B	1.20	Rp 1	Rp 1	Rp 3/8	14.0	531.5	50	269.8	219.8	126.0	95.0	142.0	109.0	191.0	160.0	65.0	73.5

CMV 5

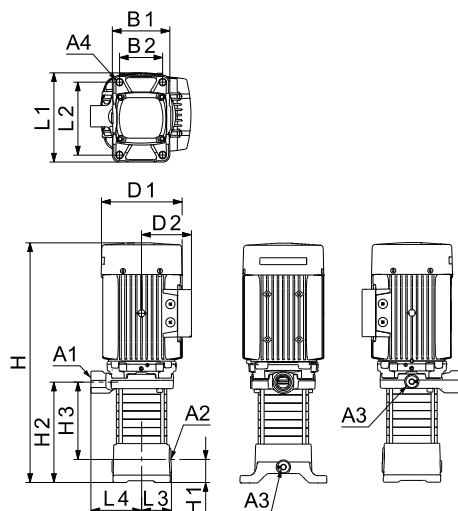

TM05 0851 1611

Dimensions

1 x 220-240 V, 50 Hz (supply voltage C)

Pump type	Frame size	P2 [kW]	Dimensions															
			A1	A2	A3	A4	H	H1	H2	H3	B1	B2	D1	D2	L1	L2	L3	L4
CMV 5-2	71B	0.5	Rp 1	Rp 1 1/4	Rp 3/8	14.0	326.7	50	125.0	75.0	126.0	95.0	142.0	133.0	191.0	160.0	65.0	73.5
CMV 5-3	71B	0.5	Rp 1	Rp 1 1/4	Rp 3/8	14.0	344.8	50	143.1	93.1	126.0	95.0	142.0	133.0	191.0	160.0	65.0	73.5
CMV 5-4	80A	0.67	Rp 1	Rp 1 1/4	Rp 3/8	14.0	402.9	50	161.2	111.2	126.0	95.0	142.0	133.0	191.0	160.0	65.0	73.5
CMV 5-5	80B	0.9	Rp 1	Rp 1 1/4	Rp 3/8	14.0	421.0	50	179.3	129.3	126.0	95.0	142.0	133.0	191.0	160.0	65.0	73.5
CMV 5-6	90SA	1.3	Rp 1	Rp 1 1/4	Rp 3/8	14.0	490.7	50	184.1	134.1	126.0	95.0	178.0	139.0	191.0	160.0	65.0	111.0
CMV 5-7	90SA	1.3	Rp 1	Rp 1 1/4	Rp 3/8	14.0	508.8	50	202.2	152.2	126.0	95.0	178.0	139.0	191.0	160.0	65.0	111.0
CMV 5-8	90SA	1.3	Rp 1	Rp 1 1/4	Rp 3/8	14.0	526.9	50	220.3	170.3	126.0	95.0	178.0	139.0	191.0	160.0	65.0	111.0
CMV 5-9	90SB	1.9	Rp 1	Rp 1 1/4	Rp 3/8	14.0	545.0	50	238.4	188.4	126.0	95.0	178.0	139.0	191.0	160.0	65.0	111.0
CMV 5-10	90SB	1.9	Rp 1	Rp 1 1/4	Rp 3/8	14.0	563.1	50	256.5	206.5	126.0	95.0	178.0	139.0	191.0	160.0	65.0	111.0

3 x 220-240 V / 380-415 V, 50 Hz (supply voltage F)

Pump type	Frame size	P2 [kW]	Dimensions															
			A1	A2	A3	A4	H	H1	H2	H3	B1	B2	D1	D2	L1	L2	L3	L4
CMV 5-2	71A	0.46	Rp 1	Rp 1 1/4	Rp 3/8	14.0	326.7	50	125.0	75.0	126.0	95.0	142.0	109.0	191.0	160.0	65.0	73.5
CMV 5-3	71B	0.65	Rp 1	Rp 1 1/4	Rp 3/8	14.0	344.8	50	143.1	93.1	126.0	95.0	142.0	109.0	191.0	160.0	65.0	73.5
CMV 5-4	80A	0.84	Rp 1	Rp 1 1/4	Rp 3/8	14.0	402.9	50	161.2	111.2	126.0	95.0	142.0	109.0	191.0	160.0	65.0	73.5
CMV 5-5	80B	1.20	Rp 1	Rp 1 1/4	Rp 3/8	14.0	441.0	50	179.3	129.3	126.0	95.0	142.0	109.0	191.0	160.0	65.0	73.5
CMV 5-6	80B	1.20	Rp 1	Rp 1 1/4	Rp 3/8	14.0	459.1	50	197.4	147.4	126.0	95.0	142.0	109.0	191.0	160.0	65.0	73.5
CMV 5-7	90SA	1.58	Rp 1	Rp 1 1/4	Rp 3/8	14.0	508.8	50	202.2	152.2	126.0	95.0	178.0	110.0	191.0	160.0	65.0	111.0
CMV 5-8	90SA	1.58	Rp 1	Rp 1 1/4	Rp 3/8	14.0	526.9	50	220.3	170.3	126.0	95.0	178.0	110.0	191.0	160.0	65.0	111.0
CMV 5-9	90SB	2.20	Rp 1	Rp 1 1/4	Rp 3/8	14.0	585.0	50	238.4	188.4	126.0	95.0	178.0	110.0	191.0	160.0	65.0	111.0
CMV 5-10	90SB	2.20	Rp 1	Rp 1 1/4	Rp 3/8	14.0	603.1	50	256.5	206.5	126.0	95.0	178.0	110.0	191.0	160.0	65.0	111.0

18. Weights and shipping volumes

All weights and volumes refer to CMV pumps with standard pipe connections.

CMV 3

Supply voltage	Pump type	Net weight [kg]	Gross weight [kg]	Shipping volume [m ³]
1 x 220-240 V, 50 Hz (supply voltage C)	CMV 3-2	12.3	14.8	0.03
	CMV 3-3	13.3	15.8	0.03
	CMV 3-4	13.6	16.1	0.03
	CMV 3-5	13.8	16.3	0.03
	CMV 3-6	15.5	18.0	0.03
	CMV 3-7	16.9	19.4	0.03
	CMV 3-8	17.1	19.6	0.03
	CMV 3-9	23.3	25.8	0.04
	CMV 3-10	27.9	30.4	0.04
	3 x 220-240 V / 380-415 V, 50 Hz (supply voltage F)	CMV 3-2	12.3	14.8
CMV 3-3		12.6	15.1	0.03
CMV 3-4		12.9	15.4	0.03
CMV 3-5		13.8	16.3	0.03
CMV 3-6		14.1	16.6	0.03
CMV 3-7		18.0	20.5	0.03
CMV 3-8		18.3	20.8	0.03
CMV 3-9		19.3	21.8	0.03
CMV 3-10		19.3	21.8	0.03

CMV 5

Supply voltage	Pump type	Net weight [kg]	Gross weight [kg]	Shipping volume [m ³]
1 x 220-240 V, 50 Hz (supply voltage C)	CMV 5-2	12.9	15.4	0.03
	CMV 5-3	13.2	15.7	0.03
	CMV 5-4	17.9	17.4	0.03
	CMV 5-5	16.2	18.7	0.03
	CMV 5-6	23.9	26.4	0.04
	CMV 5-7	24.1	26.6	0.04
	CMV 5-8	24.4	26.9	0.04
	CMV 5-9	26.2	28.7	0.04
	CMV 5-10	26.8	29.30	0.04
	3 x 220-240 V / 380-415 V, 50 Hz (supply voltage F)	CMV 5-2	12.2	14.70
CMV 5-3		13.2	15.7	0.03
CMV 5-4		17.1	19.6	0.03
CMV 5-5		17.4	19.9	0.03
CMV 5-6		17.7	20.2	0.03
CMV 5-7		24.1	26.6	0.04
CMV 5-8		24.4	26.9	0.04
CMV 5-9		28.9	31.4	0.04
CMV 5-10		29.5	32.0	0.04

19. Motor data

Mains-operated motors, 50 Hz

1 x 220-240 V, 50 Hz (supply voltage C)

Frame size	P2 [kW]	I _{1/1} [A]	Cos φ _{1/1}	I _{start} [A]	Speed [min ⁻¹]
71B	0.5	3.1 - 2.8	0.97 - 0.99	16 - 15	2730 - 2740
80A	0.7	4.4 - 4.0	0.99 - 0.99	17 - 16	2720 - 2800
80B	0.9	5.4 - 5.0	0.98 - 0.98	23 - 22	2750 - 2790
90SA	1.3	8.4 - 8.0	0.98 - 0.98	29 - 27	2710 - 2710
90SB	1.9	11.0 - 10.0	0.99 - 0.98	41 - 37	2755 - 2770

3 x 220-240 V / 380-415 V, 50 Hz (supply voltage F)

Frame size	P2 [kW]	I _{1/1} [A]	Cos φ _{1/1}	I _{start} [A]	Speed [min ⁻¹]
71A	0.5	2.0 - 2.2 / 1.0 - 1.2	0.83 - 0.75	10 - 12 / 5 - 6	2770 - 2820
71B	0.7	2.8 - 3.1 / 1.6 - 1.8	0.82 - 0.82	16 - 19 / 9 - 11	2770 - 2820
80BA	0.9	3.5 - 3.8 / 2.0 - 2.2	0.77 - 0.68	21 - 25 / 12 - 14	2840 - 2870
80C	1.2	4.8 - 5.2 / 2.8 - 3.0	0.79 - 0.70	39 - 42 / 22 - 24	2820 - 2860
90SB	1.6	5.6 - 5.4 / 3.3 - 3.0	0.88 - 0.84	46 - 44 / 27 - 25	2880 - 2910
90SC	2.2	8.2 - 8.5 / 4.7 - 4.9	0.83 - 0.75	68 - 73 / 39 - 42	2900 - 2920

20. Customisation

Although the Grundfos CMV product range offers a number of pumps for different applications, customers require specific pump solutions. Below are the options available for customising the CMV pumps. Contact Grundfos for further information or for requests other than the ones mentioned below.

Motors

Motor with multi-plug connection

Mains-operated motors fitted with a Harting® 10-pin multi-plug connection, HAN 10 ES, enable easy connection to the mains.

The purpose of a multi-plug connection is to facilitate the electrical installation and service of the pump. The multi-plug functions as a plug-and-pump device.



Fig. 22 Multi-plug logo

Plug connections

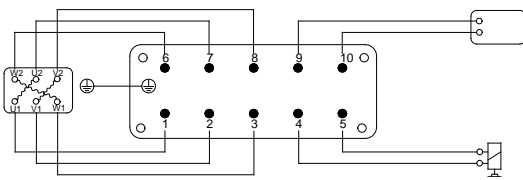

Fig. 23 Plug connection from motor

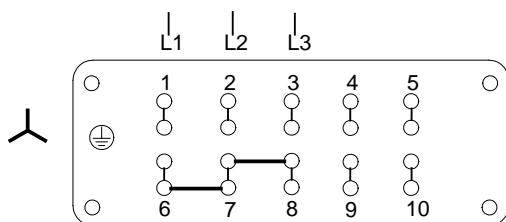

Fig. 24 Plug connection for star connection

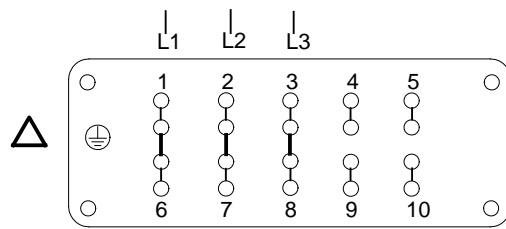

Fig. 25 Plug connection for delta connection

Note: Wire bridges for connections are located in the plug.

Motor with anti-condensation heater



Fig. 26 Mains-operated motor with anti-condensation heater

In applications where condensation in the motor may occur, we recommend to install a motor with an anti-condensation heater on the stator coil ends. The heater keeps the motor temperature higher than the ambient temperature and prevents condensation.

TM02 0470 0700

TM01 8702 0700

TM01 8703 0700

TM01 8704 0700

TM03 2440 4305

High humidity may cause condensation in the motor. Slow condensation occurs as a result of a decreasing ambient temperature; rapid condensation occurs as a result of shock cooling caused by direct sunlight followed by rain.

In areas with ambient temperatures below 0 °C, it is advisable always to use motors with anti-condensation heater.

Note: Rapid condensation is not to be confused with the phenomenon which occurs when the pressure inside the motor is lower than the atmospheric pressure. In such cases, moisture is sucked from the atmosphere into the motor through bearings, housings, etc.

In applications with constant humidity levels above 85 %, the drain holes in the drive-end flange must be open. This changes the enclosure class to IP34. If IP55 protection is required due to operation in dusty environments, it is advisable to install a motor with anti-condensation heater.

Figure 27 shows a typical circuit of a three-phase motor with anti-condensation heater.

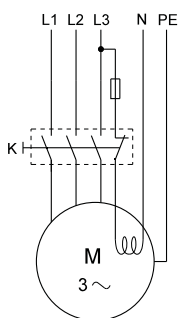

TM03 4058 1406

Fig. 27 Three-phase motor with anti-condensation heater

Legend

Symbol	Designation
K	Contactor
M	Motor

Note: Connect the anti-condensation heater to the power supply so that it is on when the motor is switched off.

The following motor sizes are available with anti-condensation heater:

Motors, 50/60 Hz	Power of heating unit [W]	
	1 x 24 V	1 x 190-250 V
Frame size		
71/80		23
90	38	31
100		38
112/132	2 x 38	2 x 38

Motors with PTC sensors



TM02 7038 2403

Fig. 28 PTC sensor incorporated in windings

Built-in PTC sensors (thermistors) protect the motor against rapid as well as slow overheating.

We offer built-in PTC sensors to protect the motor.

Mains-operated three-phase motors with supply voltages C and F of 3 kW and up have PTC sensors as standard (UL-approved motors have no internal protection).

Note: PTC sensors must be connected to an external tripping unit.

Protection according to IEC 60034-11:

- TP 211 (slow and rapid overheating).

PTC sensors comply with DIN 44082. Maximum voltage at the terminals, $U_{max.} = 2.5$ VDC. All tripping units available for DIN 44082 PTC sensors meet this requirement.

Figure 29 shows a typical circuit of a three-phase motor with PTC sensors.

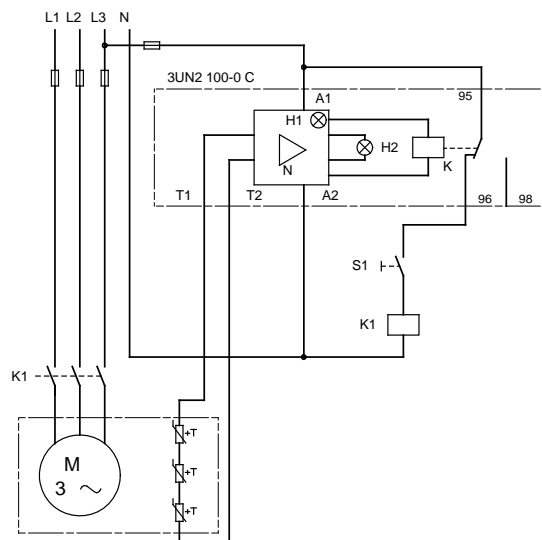

TM00 3965 1494

Fig. 29 Three-phase motor with PTC sensors

Legend

Symbol	Designation
S1	On/off switch
K1	Contactor
+T	PTC sensor (thermistor) in motor
M	Motor
3UN2 100-0 C	Tripping unit with automatic resetting
N	Amplifier
K	Output relay
H1	LED 'Ready'
H2	LED 'Tripped'
A1, A2	Connection for control voltage
T1, T2	Connection for PTC sensor loop

Motors with thermal switches



TM02 7042 2403

Fig. 30 Thermal switch incorporated in windings

Built-in thermal switches protect the motor against rapid as well as slow overheating.

We offer mains-operated motors with bimetallic thermal switches in the motor windings.

Mains-operated three-phase motors with supply voltages C and F are available with built-in thermal switches.

Note: Thermal switches must be connected to an external control circuit to protect the motor against slow overheating. The thermal switches require no tripping unit.

Protection according to IEC 60034-11:

- TP 211 (slow and rapid overheating).

As protection against seizure, the motor must be connected to a motor-protective circuit breaker.

Thermal switches tolerate the following maximum loads:

$U_{max.}$	250 VAC
I_N	1.5 A
$I_{max.}$	5.0 A (locked-rotor and breaking current)

Figure 31 shows a typical circuit of a three-phase motor with built-in bimetallic thermal switches.

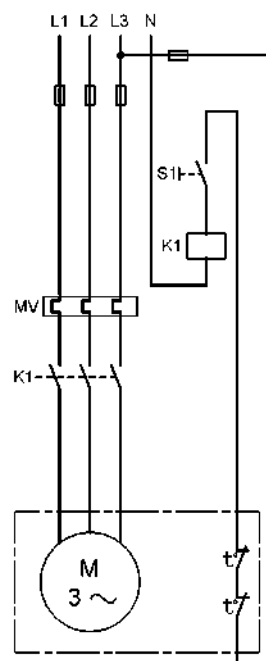

TM00 3964 1494

Fig. 31 Three-phase motor with thermal switches

Legend

Symbol	Designation
S1	On/off switch
K1	Contactor
t°	Thermal switch in motor
M	Motor
MV	Motor-protective circuit breaker

Undersize and oversize motors

The available motor sizes are shown in 19. *Motor data* on page 32.

Undersize and oversize motors are defined as the next kW size below or above the fitted standard motor.

Note: The CMV pumps cannot be combined with frame sizes 112 and 132.

It is advisable to use an oversize motor if the operating conditions fall outside the standard conditions.

We especially recommend oversize motors in these cases:

- The pump is installed at an altitude of more than 1000 metres above sea level.
- The viscosity or density of the pumped liquid is higher than that of water.
- The ambient temperature exceeds +55 °C.

It is advisable to use an undersize motor if the operating conditions do not at all reach the standard conditions.

We especially recommend undersize motors in these cases:

- The viscosity or density of the pumped liquid is lower than that of water.
- The duty point of the pump is constant, and the flow rate is significantly lower than the recommended maximum flow rate.

Pumps

Surface treatment

Cleaned and dried pumps

Cleaned and dried pumps are recommended for use in applications involving strict demands on cleanliness and surface quality, such as low content of silicone. Prior to assembly, all pump parts are cleaned in 60 to 70 °C water with a cleaning agent. All pump parts are then thoroughly rinsed in de-ionised water and air-dried. The pump is assembled without any use of silicone lubricants.

Cleaned and dried pumps are not performance-tested.

Alternative colouring

We offer custom-built pumps in any NCS- or RAL-specified colour to suit your requirements.

The used paint is water-based. Painted parts correspond to corrosion class III.

All pump types and sizes are available with alternative colouring.

Customised nameplate

We offer additional customised nameplates attached to the pump:

- A nameplate supplied by you.
- A Grundfos nameplate customised in terms of a specific duty point.
- A Grundfos nameplate with a tag number.

Note: The Grundfos standard nameplate is always fitted to the pump.

Shaft seal arrangements

The shaft seal is developed with customisation in mind. Depending on media, you may combine the seal faces in any way.

Available stationary seal faces: Q, B.

Available rotating seal faces: Q, V.

Rubber: E and V.

Note: For further details about seal face material codes, see *Type key* on page 8.

Alternative connection positions

The pump is available with various connection positions on special request.

Alternative pipe connections

A wide range of pipe connections are available for the CMV pumps:

- Tri-Clamp®
- DIN, JIS, ANSI flange
- PJE coupling (Victaulic®)
- Whitworth thread Rp
- internal NPT thread.



Fig. 32 Pipe connections

TM05 0781 1511

21. Accessories

Pipework connections

Various sets of flanges and couplings are available for pipework connection.

Distance piece

The distance piece is intended for mounting on the discharge port in order to improve the accessibility when connecting the pump to the piping system.

The distance piece is made of brass.

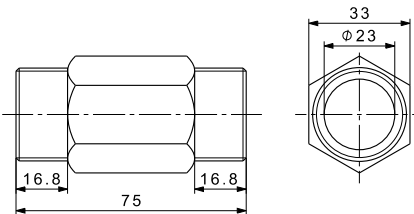
Distance piece	Pump type	Pipework connection	Pump thread	Product number
	CMV 3 CMV 5	1"	R	96587201
TM04 5800 4009				

Flange sets for CMV (DIN/ANSI/JIS)

All materials in contact with the pumped liquid are made of stainless steel, EN 1.4408/AISI 316.

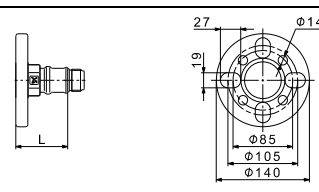
Flange	Pump type	Pipework connection	Pump thread	L* [mm]		Product number
				Flange fitted to pump inlet	Flange fitted to pump outlet	
	CMV 3	DN 32	Rp	49.0	78.0	96904693
			NPT			96904705
	CMV 5		Rp			96904696
			NPT			96904708
TM04 3867 0309						

* Length from outer edge of flange to pump suction or discharge port.

Counter flanges for CMV

Counter flanges for CMV pumps are made of cast iron, EN-GJL-200.

A counter-flange set consists of one counter flange, one gasket, bolts and nuts.

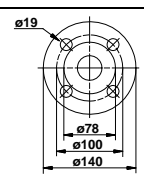
Counter flange	Pump type	Description	Rated pressure	Pipework connection	Product number
	CMV 3-A CMV 5-A	Threaded	16 bar, EN 1092-2	Rp 1 1/4	00419901
		For welding	25 bar, EN 1092-2	32 mm, nominal	00419902
TM03 0400 3705					

PJE/Victaulic® connections for CMV

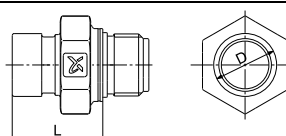
PJE connection	Pump type	Pump thread	D [mm]	L* [mm]	Product number
	CMV 3	Rp	33.7	48.5	96904694
		NPT			96904706
	CMV 5	Rp	33.7/42.4	48.5	96904697
		NPT			96904709

TMD04 3865 0309

* Length from outer edge of PJE connection to pump suction or discharge port.

Coupling, pipe stub and gasket for PJE connections

Parts in contact with the pumped liquid are made of stainless steel, EN 1.4401/AISI 316, and rubber.

A PJE coupling set consists of two coupling halves (Victaulic®, type 77), one gasket, one pipe stub (for welding or threaded), bolts and nuts.

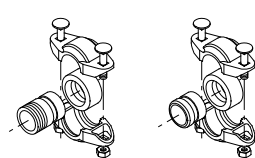
Coupling and pipe stub	Pump type	Pipe stub	Pipework connection	Rubber parts	Number of coupling sets required	Product number	
	CMV 3 CMV 5*	Threaded	R 1	EPDM	2	97575245	
					FKM	2	97575246
	For welding	DN 25			EPDM	2	97575247
						FKM	2
	CMV 5**	Threaded	R 1 1/4		EPDM	1	00419911
					FKM	1	00419905
For welding	DN 32			EPDM	1	00419912	
					FKM	1	00419904

TMD00 3808 1094

* For discharge port.

Note: Only one coupling set is required for the discharge port.

** For suction port.

Tri-Clamp® connections for CMV

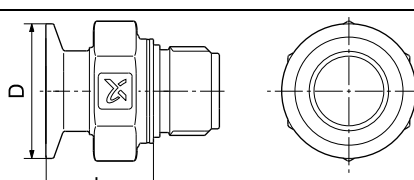
Tri-Clamp®	Pump type	Pump thread	D [mm]	L* [mm]	Product number
	CMV 3	Rp	50.4	40.3	96904695
		NPT			96904707
	CMV 5	Rp	50.4	35.3	96904698
		NPT			96904710

TMD04 3866 0309

* Length from outer edge of Tri-Clamp® connection to pump suction or discharge port.

Clamping ring, pipe stub and gasket for Tri-Clamp® connections

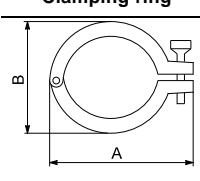
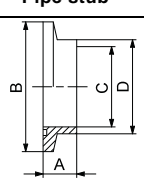
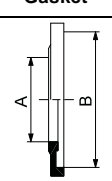
		Clamping ring		Pipe stub				Gasket	
									
Pump type	Nominal diameter [mm]	A [mm]	B [mm]	A [mm]	B [mm]	C [mm]	D [mm]	A [mm]	B [mm]
CMV 3, 5	38.0	92.0	59.5	21.5	50.5	35.6	38.6	35.3	50.5

The clamping ring is made of stainless steel, EN 1.4301/AISI 304.

The pipe stub is made of stainless steel, EN 1.4401/AISI 316.

The gasket is made of PTFE or EPDM.

Pump type	Pipework connection	Connection material	Gasket	Pressure [bar]	Number of coupling sets required	Product number
CMV 3, 5	DN 32	Stainless steel	EPDM	16	2	96515374
			PTFE		2	96515375

MP 204 motor protector



TM03 1471 2205

Fig. 33 MP 204

The MP 204 is an electronic motor protector and data collecting unit. Apart from protecting the motor, it can also send information to a control unit via GENIbus, like for instance:

- trip
- warning
- energy consumption
- input power
- motor temperature.

The MP 204 protects the motor primarily by measuring the motor current by means of a true RMS measurement.

The pump is protected secondarily by measuring the temperature with a Tempcon sensor, a Pt100/Pt1000 sensor and a PTC sensor/thermal switch.

The MP 204 is designed for single- and three-phase motors.

Note: The MP 204 must not be used together with frequency converters.

Features

- Phase-sequence monitoring
- indication of current or temperature
- input for PTC sensor/thermal switch
- indication of temperature in °C or °F
- 4-digit, 7-segment display
- setting and status reading with the Grundfos R100 remote control
- setting and status reading via the Grundfos GENIbus fieldbus.

Tripping conditions

- Overload
- underload (dry running)
- temperature
- missing phase
- phase sequence
- overvoltage
- undervoltage
- power factor (cos φ)
- current unbalance.

Warnings

- Overload
- underload
- temperature
- overvoltage
- undervoltage
- power factor (cos φ)
- run capacitor (single-phase operation)
- starting capacitor (single-phase operation)
- loss of communication in network
- harmonic distortion.

Learning function

- Phase sequence (three-phase operation)
- run capacitor (single-phase operation)
- starting capacitor (single-phase operation)
- identification and measurement of Pt100/Pt1000 sensor circuit.

Product number

Description	Product number
MP 204 motor protector	96079927

Cover for CMV motor

The cover protects the motor from ingress of liquid, especially if the pump is installed in a vertically tilted position with the motor end pointing upwards.

Product number

Description	Product number
Cover for CMV motors, frame sizes 71 and 80	97528743

Angled cable gland



TM05 0729 1411

Fig. 34 Angled cable gland with O-ring and lock nut

Description	Product number
Angled cable gland with O-ring and lock nut	97842998

22. Further product documentation

WebCAPS

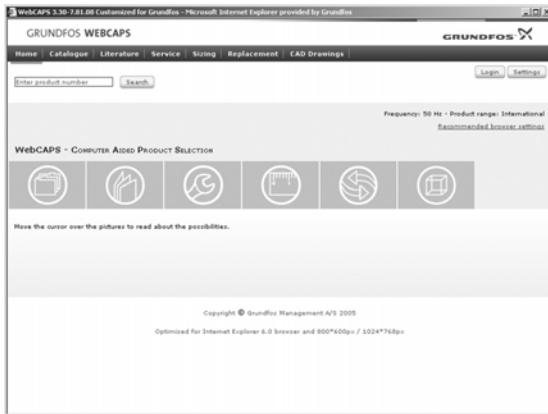

WebCAPS is a **Web**-based **Computer Aided Product Selection** program available on www.grundfos.com. WebCAPS contains detailed information on more than 220,000 Grundfos products in more than 30 languages.

Information in WebCAPS is divided into six sections:

- Catalogue
- Literature
- Service
- Sizing
- Replacement
- CAD drawings.

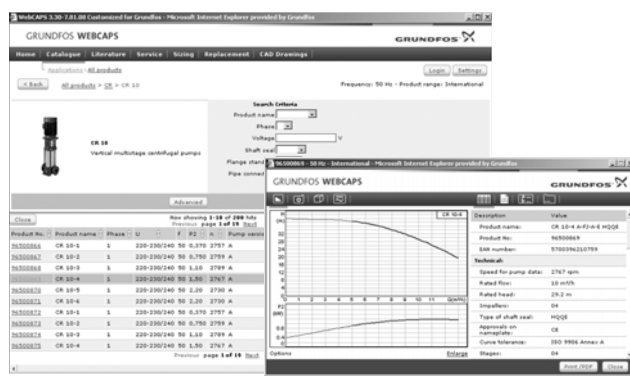

Catalogue

Based on fields of application and pump types, this section contains the following:

- technical data
- curves (QH, Eta, P1, P2, etc.) which can be adapted to the density and viscosity of the pumped liquid and show the number of pumps in operation
- product photos
- dimensional drawings
- wiring diagrams
- quotation texts, etc.

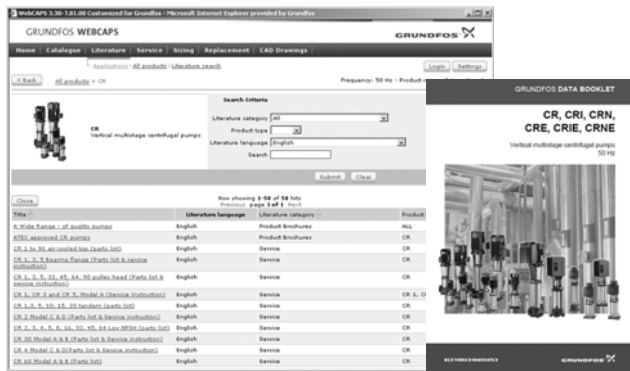

Literature

This section contains all the latest documents of a given pump, such as

- data booklets
- installation and operating instructions
- service documentation, such as Service kit catalogue and Service kit instructions
- quick guides
- product brochures.



Service

This section contains an easy-to-use interactive service catalogue. Here you can find and identify service parts of both existing and discontinued Grundfos pumps.

Furthermore, the section contains service videos showing you how to replace service parts.



Sizing

This section is based on different fields of application and installation examples and gives easy step-by-step instructions in how to size a product:

- Select the most suitable and efficient pump for your installation
- Carry out advanced calculations based on energy consumption, payback periods, load profiles, life cycle costs, etc.
- Analyse your selected pump via the built-in life cycle cost tool
- Determine the flow velocity in wastewater applications, etc.



Replacement

In this section you find a guide to selecting and comparing replacement data of an installed pump in order to replace the pump with a more efficient Grundfos pump. The section contains replacement data of a wide range of pumps produced by other manufacturers than Grundfos.

Based on an easy step-by-step guide, you can compare Grundfos pumps with the one you have installed on your site. When you have specified the installed pump, the guide will suggest a number of Grundfos pumps which can improve both comfort and efficiency.

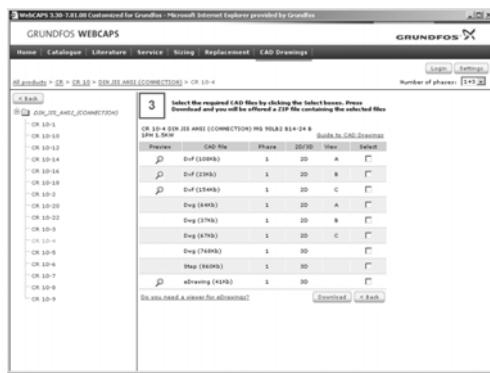

CAD drawings

In this section, it is possible to download 2-dimensional (2D) and 3-dimensional (3D) CAD drawings of most Grundfos pumps.

These formats are available in WebCAPS:

- 2-dimensional drawings:
- .dxf, wireframe drawings
 - .dwg, wireframe drawings.
- 3-dimensional drawings:
- .dwg, wireframe drawings (without surfaces)
 - .stp, solid drawings (with surfaces)
 - .eprt, E-drawings.

WinCAPS



Fig. 35 WinCAPS CD-ROM

WinCAPS is a **Windows-based Computer Aided Product Selection** program containing detailed information on more than 220,000 Grundfos products in more than 30 languages.

The program contains the same features and functions as WebCAPS, but is an ideal solution if no internet connection is available.

WinCAPS is available on CD-ROM and updated once a year.

Subject to alterations.

97942071 0611

Repl. 97942071 0511

GB

ECM: 1076991

The name Grundfos, the Grundfos logo, and the payoff Be-Think-Innovate are registered trademarks owned by Grundfos Management A/S or Grundfos A/S, Denmark. All rights reserved worldwide.